

DIGITAL PLATESETTER

# Luxel T-9000CTP HS

ST  
AR  
T  
UP  
O



DIGITAL

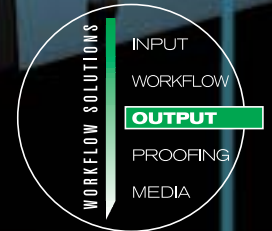

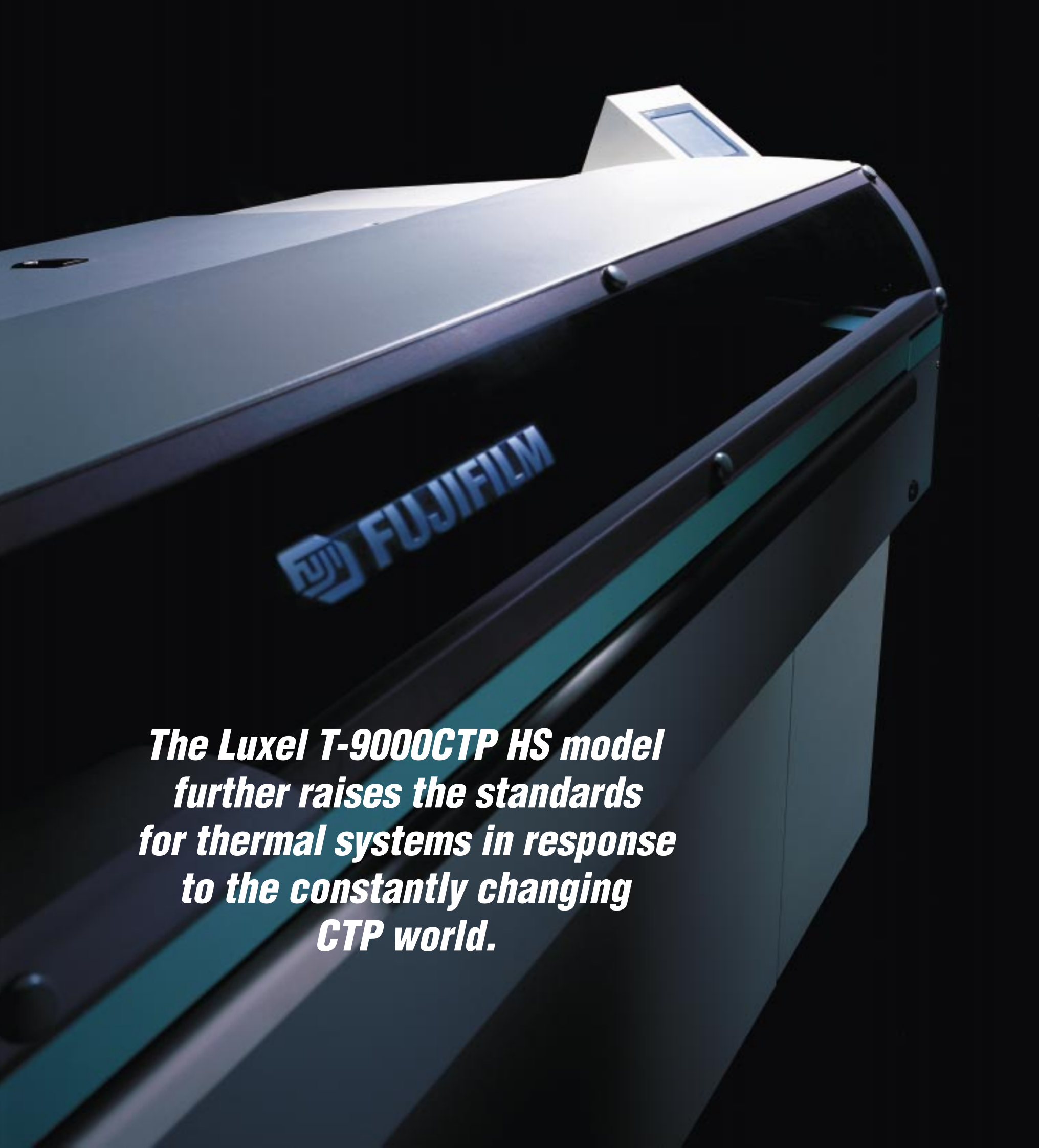

***The Luxel T-9000CTP HS model further raises the standards for thermal systems in response to the constantly changing CTP world.***

***Designed to Meet Your Needs with the Optimum Combination of High Speed, Accuracy and Automation***

**F**ujifilm works tirelessly to provide customers with comprehensive CTP solutions including a full range of platesetters, digital plates and innovative applications backed by its customer support network.

The Luxel T-9000CTP HS model is Fujifilm's latest thermal CTP system. Building on the proven advantages of the Luxel T-9000CTP including easy handling in white light and high quality, it offers improved productivity with faster processing capabilities and the ability to handle a wide range of plate sizes from GTO-size to 8-up, providing versatile CTP solutions for both web and sheet-fed presses.

The Luxel T-9000CTP HS confirms Fujifilm's reputation for high-volume productivity, quality, reliability, and convenience in CTP solutions. Once again, Fujifilm CTP solutions are leading the way.

**See the difference for yourself!**

- High-speed throughput of 20 plates/hour at 2400 dpi.
- Uniform exposure on a wide range of thermal plates from GTO-size to 8-up.
- Easy expansion to simplify operation with an online plate processor and autoloader.
- Exceptional image quality using Fujifilm's proven LH-NI and LH-PIE thermal plates on the market.
- Increased efficiency and precision with the optional Automatic Internal Punch.



**Thermal Digital Platesetter**



## 20 Plate/Hour Output Using a 64-Channel Imaging Head

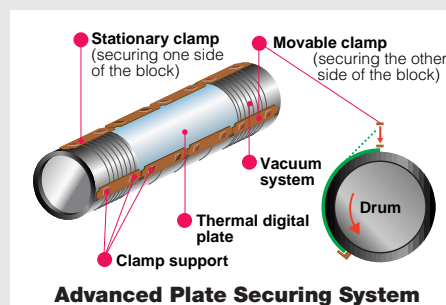

**Advanced Plate Securing System**

thermal plates (8 up) per hour at 2,400 dpi.

Superior high-precision lightweight clamping technologies

Combining a 64-channel Multi-Exposure System and an ultra-fast rotation of 1,000 rpm, the Luxel T-9000CTP HS enhances productivity, realizing high-speed output of 20

and an advanced vacuum system ensure that plates are set firmly and accurately. The Luxel T-9000CTP HS uses an innovative external drum recording system that is the key to maximizing both drum rotation speed and imaging accuracy.

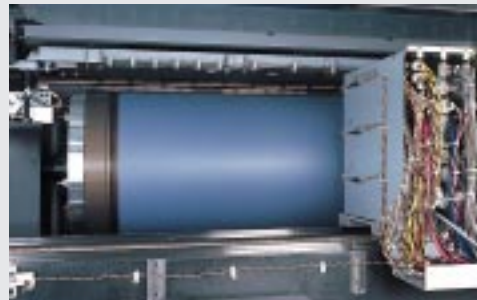

## Improving Press Versatility and Ease of Use

### Variable clamping and drum autobalance

Fujifilm improves the unique Variable Positioning Clamping System and innovative Drum Autobalance System for responding to requirements for press versatility as well as simple, easy-to-use operation. By using the unprecedented Variable Clamping System to secure plates automatically, the Luxel T-9000CTP HS is the perfect solution for all your plate sizes from GTO-size (500 x 370 mm/19.6 x 14.5 inch) all the way up to 8-up plates (1,160 x 940 mm/45.6 x 37.0 inch). It also handles plates as thin as 0.15 mm/5.9 mil and as thick as 0.3 mm/11.8 mil. To compensate for the differences among plates, the Drum Autobalance System makes minute adjustments to set the perfect drum balance for each size. It's your assurance of super-fast and absolutely consistent laser exposure.

### Smaller clamp size

The Luxel T-9000CTP HS also provides solutions to most web offset press requirements for the maximum imaging area by minimizing clamp sizes as low as 8 mm\*. This versatility allows it to cover the requirements of both web and sheet offset presses. Note: Normal clamp size is 12 mm. When the clamp size is 8 mm, productivity is reduced.

### Optional automatic internal punch

Add the optional Automatic Internal Punch for even total through-

put. You can choose from a number of blocks to punch plates automatically and accurately immediately prior to exposure. Along with simplifying CTP processing, this feature saves time and improves repeatability.



### White-light convenience and automated operation

Handling is easy since thermal plates can be used in yellow light or ultraviolet-filtered white light. Along with eliminating bother, they minimize processing time and special training. Just slip a plate into the guides, and let the Luxel T-9000CTP HS take over. Every step is automatic – winding, laser exposure and unloading.

### Effortless control means a better workflow

Simply input the plate size, resolution and other settings on the LCD control panel. Only a few touches are all it requires for easy and continuous processing.



and there's no better match than the latest addition to Fujifilm's platesetter lineup.

## The Synergy of Quality

From the very beginning, development of the Luxel T-9000CTP series was fine-tuned to get more from Fujifilm LH-NI and LH-PIE thermal plates. They've already set the standard for image quality,

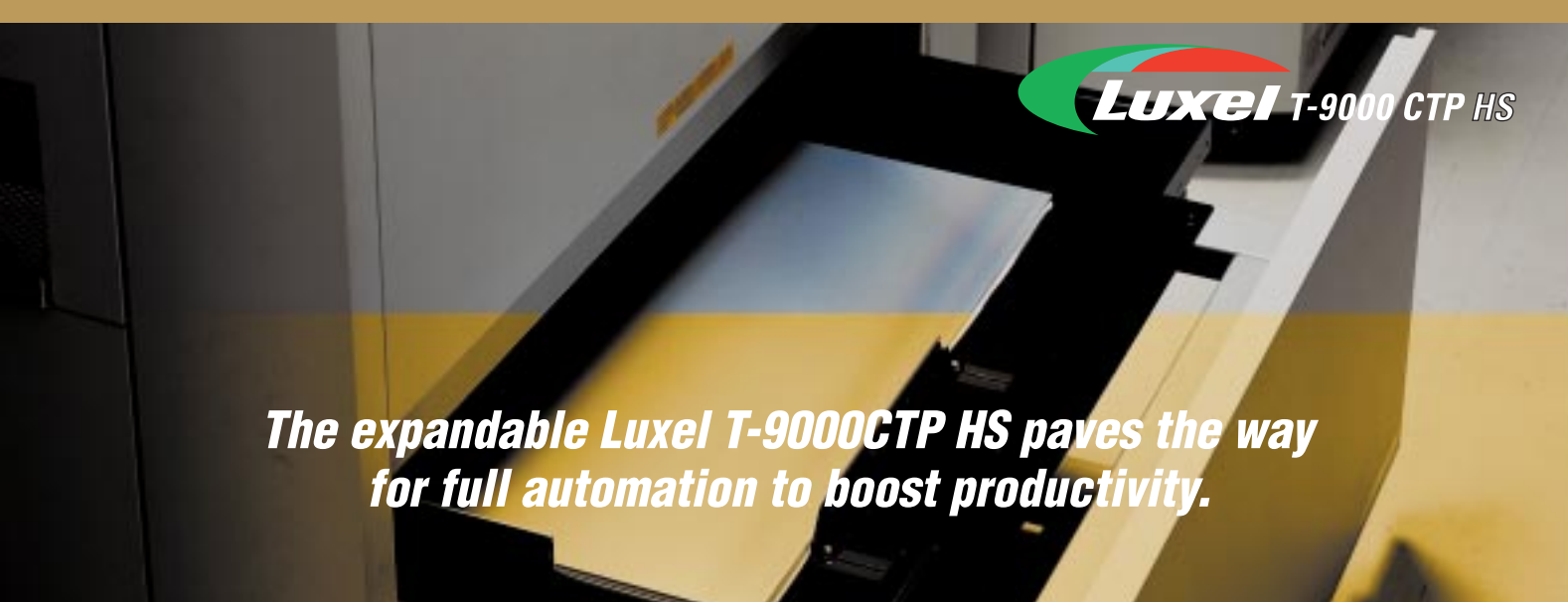

*The expandable Luxel T-9000CTP HS paves the way for full automation to boost productivity.*

## Ready for Tomorrow

Think of the Luxel T-9000CTP HS as the hub of a productivity-boosting system. With optional T-9000 AL II (single-cassette autoloader), T-9000 ML II (multi-cassette autoloader) and plate processors, it has the made-for-tomorrow expandability that raises the productivity of your entire operation and lowers your costs.

The multi-cassette autoloader with its maximum five-cassette capacity accepts plates of varying sizes for continuous processing of consecutive jobs. With each cassette holding 100 plates, the five-cassette autoloader provides up to 500-plate capacity.

The automatic plate loaders feature an interleaf removal system that automatically routes paper to the disposal area and plates to the platesetter. Since plates are vacuum-gripped from the back for transport, there is no risk of scratching. The addition of these options paves the way for full automation, a distinct advantage of the Luxel T-9000CTP series. And single-autoloader systems can be easily upgraded to function with the multi-cassette autoloader.

### Luxel T-9000CTP HS With Full Options

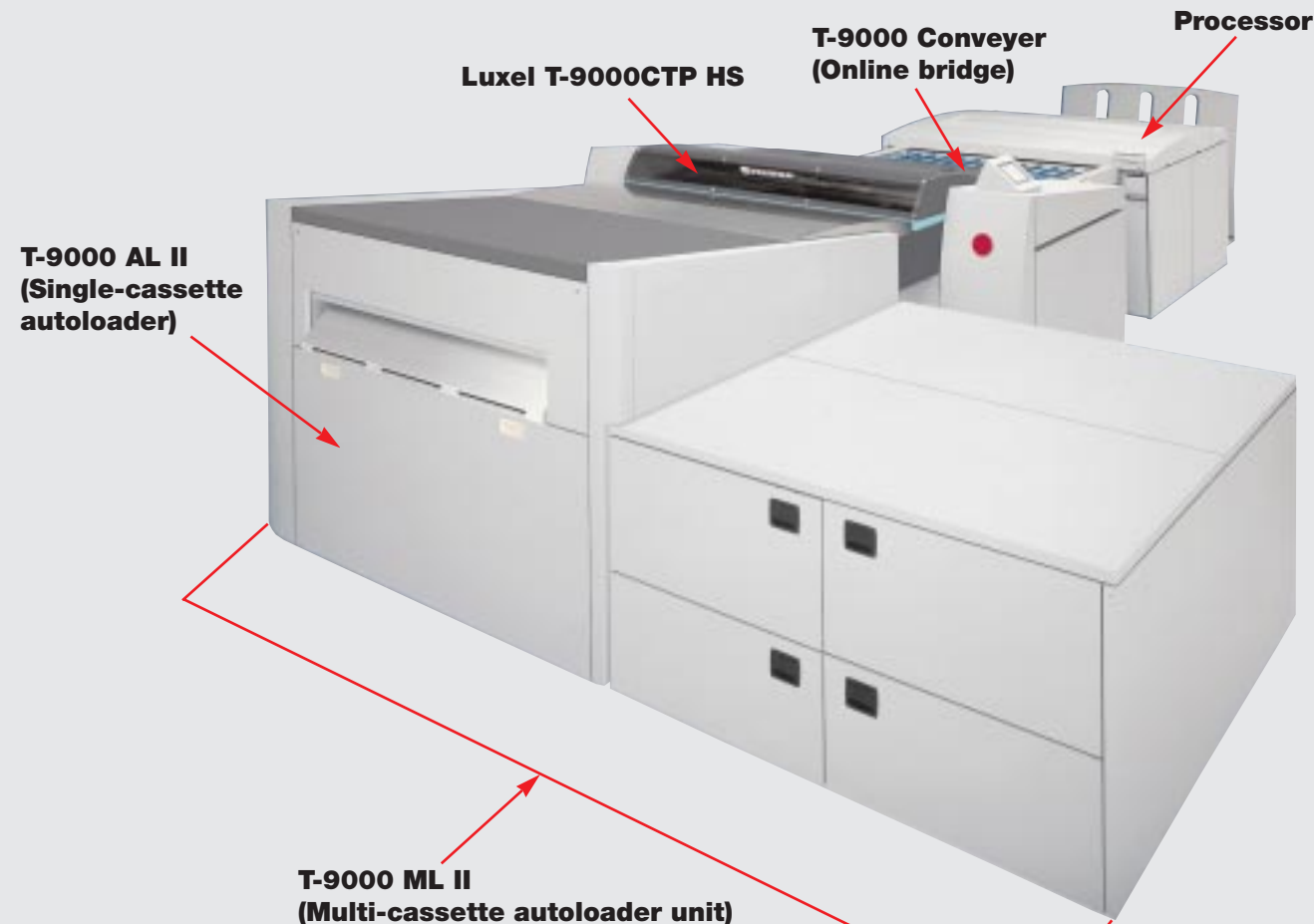

*Luxel T-9000CTP HS satisfies the requirement for high-volume plate production with unmatched accuracy and even shorter turnaround times*

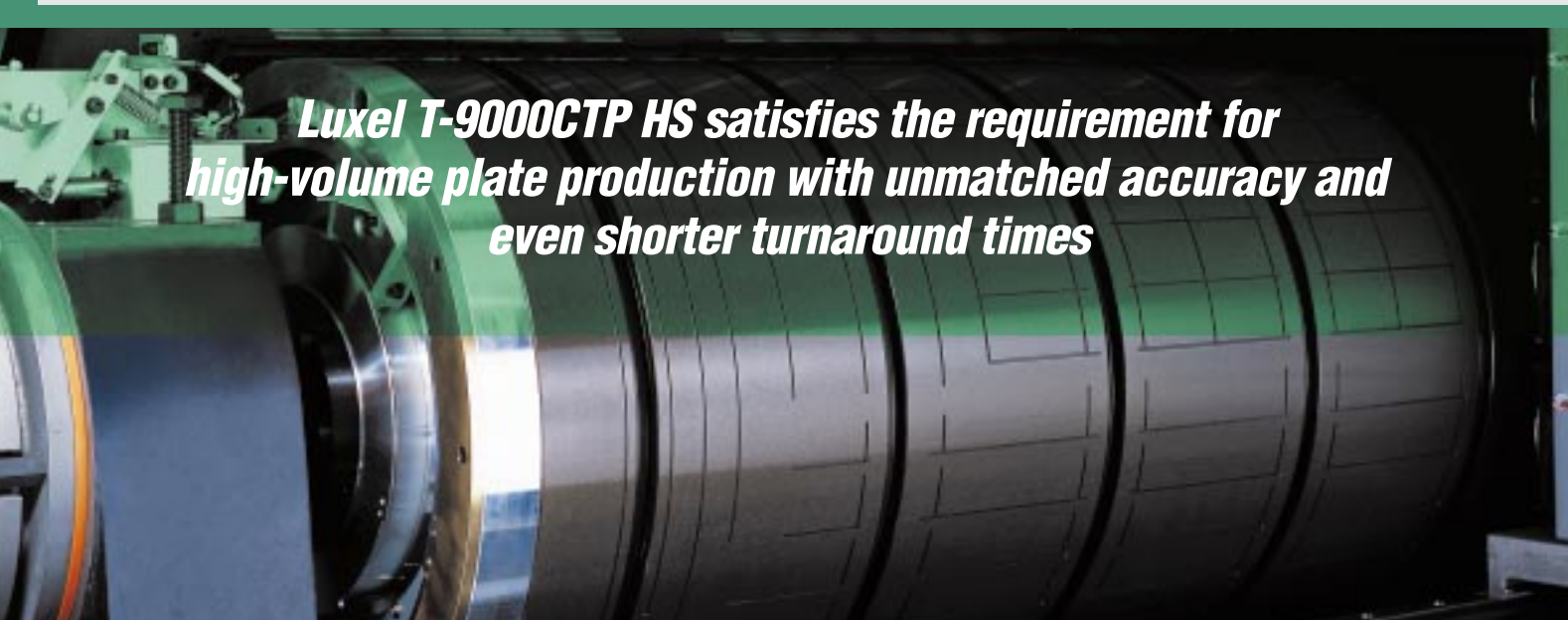

**Fujifilm provides complete solutions, creating advanced software as well as media and system hardware, for the optimum workflow.**

## Celebrant Extreme – A Major Step Forward

### Fujifilm Celebrant Extreme RIP

Celebrant Extreme is a flexible workflow system based on the powerful Adobe® Extreme printing architecture: it takes full advantage of the increased processing power of PCs, and the new generation of high speed output devices. With its flexible modular design incorporating PDF preparation, ripping and workflow server elements, Celebrant Extreme enables users to start with a basic RIP and upgrade to a full workflow server system with multiple RIPs for multiple output devices.

- Supports Adobe PostScript 3™ and the new PDF version 1.4 format
- Client-server workflow for multiple remote access of RIP from Macintosh® and PC workstations
- Automated preparation of PDF files, including pre-flighting
- Job Ticket system with comprehensive set-up options
- ICC color management from scanning to printing
- Divides multi-page documents into individual pages for ripping, allowing late page editing and changes to imposition without having to re-RIP entire jobs
- Zonal trapping option



### Co-Res Screening

Co-Res screening\* is a performance-enhancing option enabling 300lpi printing with common resolution at 2400/2438 dpi output and 175lpi printing at 1200/1219 dpi output.

Employing unique technology from the analysis of output devices, materials and human eyesight characteristics, the Co-Res screening data simulation and feedback architecture generates half tone dots with optimum image quality.

\* Common resolution screening

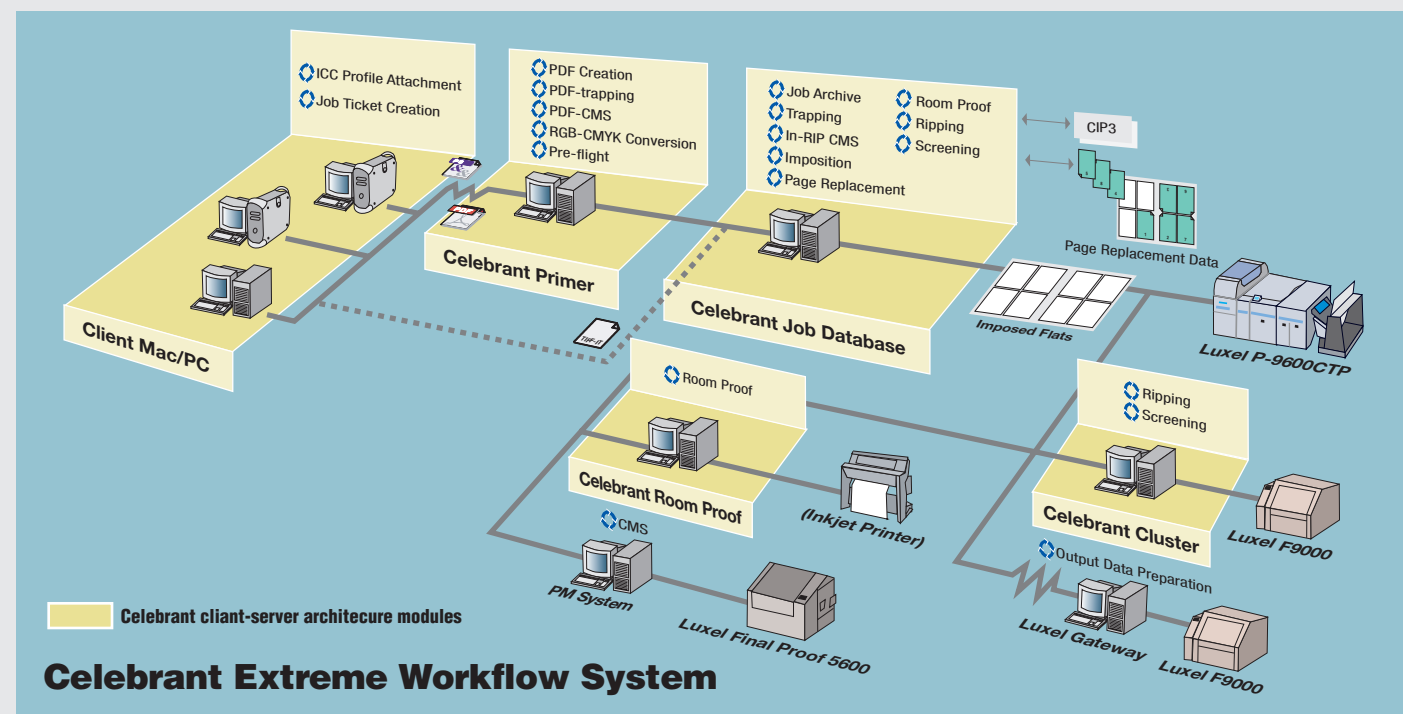

### Positive Digital Thermal Plate Brillia LH-PIE

#### Save time and space

With the Brillia LH-PIE plate, you don't need an oven for pre-heating. Along with simplifying processing, it reduces your space requirements.

#### Outstanding gradation accuracy

You can count on sharp output that captures all the subtleties. Along with featuring high resolution of 200 lpi, Fujifilm thermal plates deliver 1 – 99% halftone gradations.

#### Multigrain quality and efficiency

The exclusive Multigrain base creates the same printing conditions as a conventional PS-Plate. It makes Fujifilm thermal plates the clear-cut choice when you want a better work environment, easier handling and PS plate quality.

#### Straightforward white-light handling

Fujifilm's thermal plates define a long stride forward in convenience and productivity. Since they respond to infrared laser energy instead of visible laser light, you can get out of the darkroom and use them in yellow light or ultraviolet-filtered white light.

#### Quality meets durability in medium runs

Without baking, the LH-PIE and LH-NI thermal plates give 200,000 high-quality impressions. Even when you use UV ink, the LH-PIE lasts for 100,000 – 200,000 impressions. With baking, the LH-NI thermal plate can deliver 1 million impressions.

#### Thermal digital plate processing

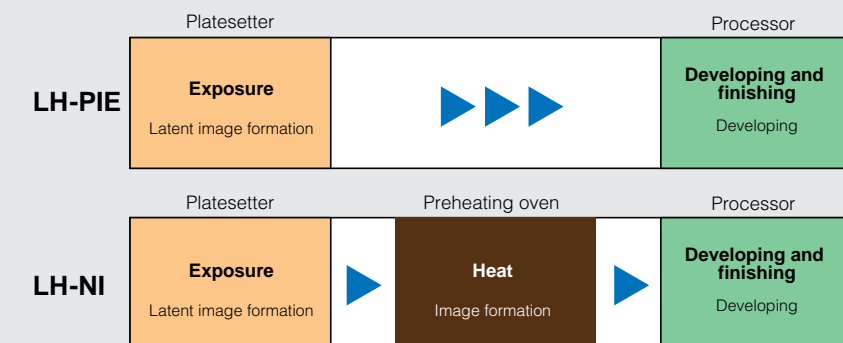

### LH-PIE's EDL Technology Enhanced Development Layer

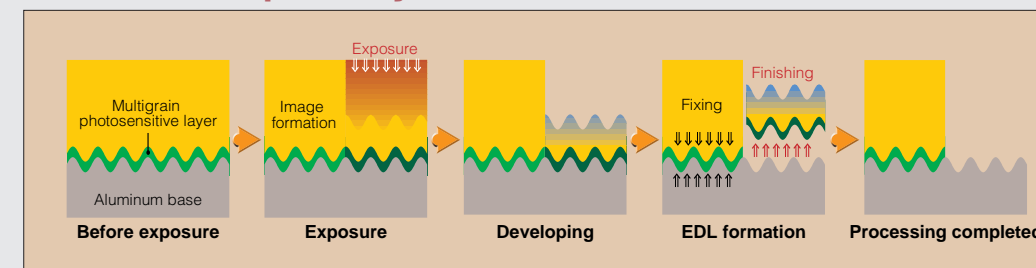

### Improved durability and UV ink compatibility

The LH-PIE's strength and versatility lies in its island method. A key to the LH-PIE's enhanced chemical-resistance and durability, this technique deposits imaging resin on a long-lasting, readily soluble binder made of chemical resin. It also accounts for the LH-PIE's compatibility with UV ink without baking. Even though the LH-NI doesn't use an island method, it also works with UV ink with baking.

### Specifications

**Brillia Digital Thermal Plates LH-PIE Positive and Brillia LH-NI Negative** •Base: Aluminum base with exclusive Multigrain structure •Sensitivity: Infrared laser light source: 800 – 850 nm •Resolution: 200 lpi, 1–99% •Run length: LH-NI: 200,000 impressions (up to 1 million with baking\*)/LH-PIE: 200,000 impressions

\* With coated paper

**Like you, Fujifilm puts quality first. That's why our digital thermal plates are broadening the possibilities in CTP to help our customers get where they want to go.**

## SPECIFICATIONS

### LUXEL T-9000CTP HS

<b>Recording system</b>	External drum
<b>Media</b>	Fujifilm's LH-PIE positive and LH-NI negative thermal plates
<b>Plate size</b>	Maximum: 1,160mm × 940mm (45.6" × 37.0") Minimum: 500mm × 370mm (19.6" × 14.5")
<b>Exposure size</b>	Maximum: 1,160mm × 924mm (45.6" × 36.3") Minimum: 500mm × 354mm (19.6" × 13.9") Min. clamping size (around the drum) is 16mm (min. clamping size 8mm at each end) or 24mm (normal clamping size 12mm at each end) smaller than the plate size depending on the plate size and productivity required.
<b>Plate thickness</b>	0.15mm–0.3mm (5.9mil–11.8mil)
<b>Light source</b>	Infrared 830 nm LD, 64 ch, 500mW/1 ch
<b>Resolution</b>	1,200 / 2,000 / 2,400 / 2,438 / 2,540 / 4,000 dpi
<b>Repeatability</b>	±5 micrometers (±0.2 mil)*1
<b>Productivity</b>	20 plates (1,030mm × 800mm) per hour at 2,400 dpi*2
<b>RIP interface</b>	Fast PIF interface
<b>Plate transport</b>	Manual front loading and unloading
<b>Punch (optional)</b>	Bacher, Protocol, Komori, Screen and others
<b>External dimensions</b>	Main unit: 2,420mm (W) × 1,285mm (H) × 1,295mm (D) 95.2" (W) × 50.5" (H) × 50.9" (D) (excluding plate loading and unloading trays) Vacuum: 695mm (W) × 550mm (H) × 710mm (D) 27.4" (W) × 21.6" (H) × 28.0" (D) (excluding plate loading and unloading trays)
<b>Weight</b>	Main unit: Approx. 1,150 kg Vacuum unit: Approx. 85 kg
<b>Environment</b>	23°C ±2°C (73.4°F ±3.6°F), 40-70% RH
<b>Power requirements</b>	Main unit: AC200V–230V±10%, single phase, 50/60Hz, 5kVA
<b>Options</b>	Online conveyer, single-cassette autoloader/ multi-cassette autoloader

Specifications and design are subject to change without notice.

\*1 Over four consecutive exposures on one plate at 23°C and 60% relative humidity.

\*2 Output speed may vary depending on the clamp sizes at top and bottom.

### T-9000 AL II (SINGLE-AUTOLOADER FOR LUXEL T-9000CTP HS)

<b>Cassette capacity</b>	100 plates
<b>Plate size</b>	Maximum: 1,160mm × 940mm (45.6" × 37.0") Minimum: 500mm × 370mm (19.6" × 14.5")
<b>Plate thickness</b>	0.15mm–0.3mm
<b>Dimensions</b>	1,758mm (W) × 1,295mm (H) × 1,777mm (D) 69.2" (W) × 51.0" (H) × 70.0" (D)
<b>Weight</b>	Approx. 600kg

### T-9000 ML II (MULTI-AUTOLOADER FOR LUXEL T-9000CTP HS)

<b>Components</b>	T-9000 ML II consists of T-9000 AL II and cassette cabinet.
<b>Plate size</b>	Maximum: 1,160mm × 940mm (45.6" × 37.0") Minimum: 500mm × 370mm (19.6" × 14.5")
<b>Plate thickness</b>	Maximum: 0.3mm Minimum: 0.15mm
<b>Plate transportation</b>	Automatic with interleaf paper removal function
<b>Number of plate cassettes</b>	3 cassettes as standard 2 cassettes can be added as option
<b>Plate cassette capacity</b>	100 plates per cassette The cassette can hold only one size of the plate.
<b>Dimensions</b>	Whole T-9000 ML II 3,213mm (W) × 1,295mm (H) × 1,777mm (D) 126.5" (W) × 51.0" (H) × 70.0" (D) T-9000 AL II part: 1,758mm (W) × 1,295mm (H) × 1,777mm (D) 69.2" (W) × 51.0" (H) × 70.0" (D) Cabinet part: 1,524mm (W) × 855mm (H) × 1,777mm (D) 60.0" (W) × 33.7" (H) × 51.0" (D) Required door way 1,550mm (W) × 1,310mm (H) 61.0" (W) × 51.6" (H)
<b>Weight</b>	1,200kg (T-9000 AL II: 600kg, Cabinet: 600kg)

Specifications and design are subject to change without notice.

## DIMENSIONS

Unit: mm (inch)

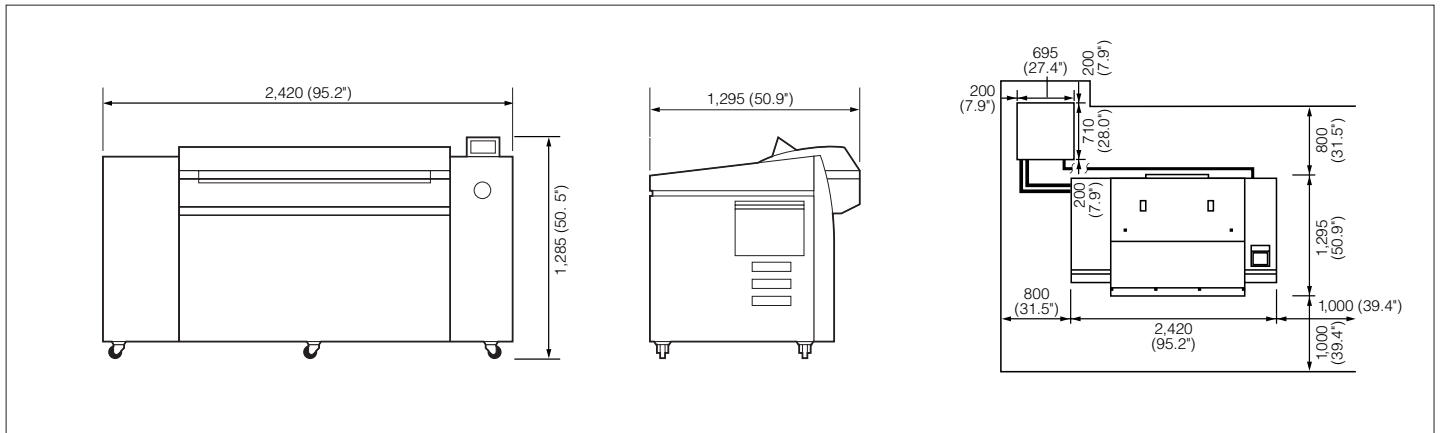

Adobe™ and PostScript™ are registered trademarks of Adobe Systems Inc.  
Windows® is a registered trademark of Microsoft Corp.  
All other trademarks are the property of their respective holders.

**FUJIFILM**  
FUJI PHOTO FILM CO., LTD.

26-30, NISHIAZABU 2-CHOME, MINATO-KU, TOKYO 106-8620, JAPAN

Ref. No. GB-151E (SK-01-10-DT-MW) Printed in Japan © 2001 Fuji Photo Film Co., Ltd.